

Design of Ergonomic Emergency Car Toilet Seats as a Solution to Severe Traffic in Jakarta, Indonesia

Dessy Laksyana Utami¹, Aisy Luthfianisa Putri²,
Adi Heru Sutomo³, and Ketut Ima Ismara⁴

¹Graduate School of Environment Science, Yogyakarta, Jl. Bulak Sumur, Indonesia

²Faculty of Medicine, Public Health & Nursing, Universitas Gadjah Mada Yogyakarta, Jl. Bulak Sumur, Indonesia

³Faculty of Medicine, Public Health & Nursing, Universitas Gadjah Mada Yogyakarta, Jl. Bulak Sumur, Indonesia

⁴Faculty of Engineering, Universitas Negeri Yogya Yogyakarta, Jl. Bulak Sumur, Indonesia

ABSTRACT

This research aims to create an ergonomic emergency toilet design on car seats. This system can offer more convenience and comfort for car drivers stuck in traffic jams for hours. Background: Congestion in Jakarta is one of the few problems the government has not resolved to date. The leading cause is the amount of transportation. Reducing the use of private vehicles, such as cars or motorbikes, and the number of people in Jakarta is very anxious because traffic congestion in Jakarta and surrounding areas is worsening. Even the highways used to free us from traffic obstructing our roads because cars are everywhere. This situation can be a problem when using the toilet where the driver is stuck in traffic for hours. This method induces discomfort and causes urinary system disorders and bladder disease. Method: To design an emergency toilet system on a car seat, an ergonomic approach introduces a new design concept for car drivers and passengers. Using this toilet system, users do not need to get out of the car, but simply opening the hole cover in the seat can be used easily and more comfortably. Result: Emergency toilet on the car seat. Passengers can also use this because it is made on every seat in the car.

Keywords: Emergency toilet, Toilet car, Traffic jam jakarta, Ergonomic toilet, Toilet design

INTRODUCTION

Economic activity is a sign of a thriving economy. This is also evident in other aspects of city development, such as new residential areas, industrial zones, and commercial zones. Transportation is needed to support such urban activities.

Transportation is indispensable in economics as a derived demand for economic, social, and other activities. A growing population will also increase the number of people moving. If there is a stagnation in traffic signals by the motion of the cars, the situation is known as a traffic jam. It has become

a severe problem in Jakarta. Ironically, our country's public transportation service system is underutilized compared to cities in developed countries.

People in developed countries tend to use public transport more than private vehicles. Throughout the city of Jakarta, However, most people prefer to use privately owned cars over public transportation.

Reasons include discomfort, longer travel times, inadequate public transportation capacity, and insufficient security. Furthermore, Jakarta is building many road infrastructures, originally designed to facilitate traffic, but congestion is worsening because construction is conducted in congested conditions. A steady increase in the number of private transportation users, which usually continues from year to year, when not supported by adequate infrastructure development, can create a whole new set of problems, such as traffic congestion. Nearly all the people in Jakarta rely on motorized vehicles for their transportation.

They are a part of human life and cannot be separated. As Jakarta's population and economic level increase, the demand for motorized vehicles will also increase.

People in the lower middle class prefer motorbikes because they are relatively cheaper than cars and pass through busy, minor roads. However, their limited carrying capacity often disturbs their use. So, four-wheeled vehicles are usually preferred.

A car must provide comfort and safety for its driver and passengers since many people will use it. Increasing traffic jams and the long time it takes for users of four-wheeled vehicles to arrive at their destinations has resulted in a new problem - the need for toilets. The toilet is one of the basic needs of human beings.

The existence of one of these facilities is essential. A design for a car seat that features an emergency toilet for drivers and passengers to use during traffic jams in Jakarta has been developed to solve this problem. Due to the above background and phenomena, the writer is interested in researching the subject "*Design of Ergonomic Emergency Car Toilet Seats as A Solution to Severe Traffic In Jakarta, Indonesia*".

RESEARCH METHODOLOGY

This investigation falls under research and development (Research and Development). The respondents are private vehicle/car users, both drivers and passengers, and the product under consideration is a car seat emergency toilet design. In this study, the 4-D development approach (Trianto, 2010) was used, which consists of four stages: stage I define, stage II design, stage III develops, and stage IV disseminate. However, the research step in this study was limited to stage II design, i.e., creating the product without proceeding to the development and distribution stages.

This study begins with determining the research topic: designing an emergency toilet seat or car seat using ergonomic principles to be used comfortably and safely. The next step is to conduct a literature and field study to determine the current condition and emergency design of the toilet seat/car seat. The third step is to identify and formulate the problem: an emergency toilet

Table 1. Anthropometric dimension (Chuan, Markus, & Naresh 2010).

No.	Dimensi	Male				Female			
		5th	50th	95th	SD	5th	50th	95th	SD
1	Tinggi badan duduk/Sitting height	80	89	96	5.24	78	83	90	4.7
2	Tinggi mata/Sitting eye height	69	76	84	4.58	67	73	80	5.83
3	Tinggi bahu duduk/Sitting Shoulder Height	52	59	67	6.27	51	56	63	4.94
4	Tinggi siku duduk/Sitting elbow height	19	24	30	4.74	19	25	32	5.19
5	Jarak siku ke ujung jari/Elbow-fingertip height	42	47	56	4.55	37	43	50	4.27
6	Tinggi Paha Bawah Dari Lantani/Popliteal Height	38	44	49	3.78	38	44	50	3.92
7	Jarak bokong ke lutut depan/Buttock-knee length	48	56	64	4.89	45	53	60	4.81
8	Jarak bokong ke lutut belakang/Buttock-popliteal length	40	46	54	4.82	37	43	51	4.21
9	Tebal paha/Thigh tickness	12	16	22	3.59	11	15	19	3.22
10	Tebal perut/Abdominal depth	15	21	29	4.46	14	18	25	3.44
11	Lebar Bohu/Shoulder breadth	36	45	52	4.66	37	43	53	5.43
12	Lebar Bokong/Hip breadth	28	35	43	4.41	29	35	45	7.22
13	Lebar telapak kaki/Foot breadth	8	10	12	3.96	7	9	11	2.2
14	Panjang telapak kaki/Foot length	22	25	29	2.58	21	23	26	2.63
15	Berat Badan/Body weight (Kg)	50	63	89.25	13.19	39.80	53	80	11.68

seat/car seat comfortable for both the driver and passengers. Furthermore, the objectives and benefits of this research are determined.

Anthropometric Data

Anthropometric data used in this study is Indonesian anthropometric data, which refers to the journal *Anthropometry of the Singaporean and Indonesian Populations* by Chuan, Markus, and Naresh (2010), specifically anthropometric data of Indonesians aged 18 to 45 years. Sitting height, sitting eye height, sitting shoulder height, sitting elbow height, elbow distance to fingertips, lower thigh height from the floor, buttocks to front knee distance, buttocks to back knee distance, thigh thickness, belly thickness, shoulder width, buttocks width, foot width, foot length, and body weight are the dimensions that will be used.

The average value and standard deviation for these components will apply anthropometric data. According to *Anthropometry*, the 5th percentile represents a small body size, the 50th percentile represents an average body size, and the 95th percentile represents a large body size.

Type Y Vehicle Seat Dimension Data

According to the investigation, the second row of seats is designed for two people, with a hand rest in the middle of the back.

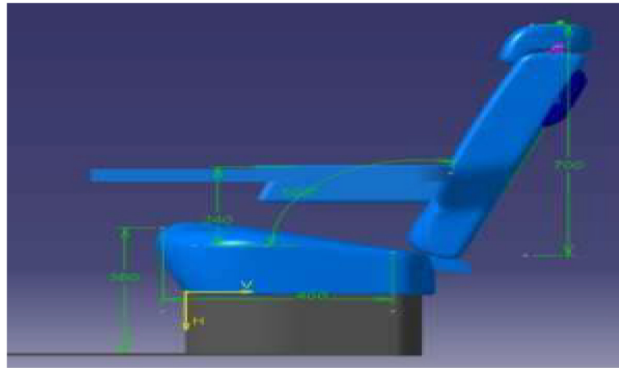

Figure 1: Second row seat dimensions.

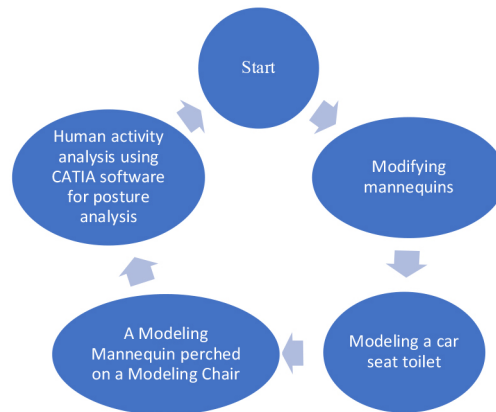

Figure 2: Stages of modeling.

However, the capacity of the second row of seats can be increased to three people by folding the handrest in the middle of the seat backrest. The middle seat functions as a spare seat by increasing the passenger capacity of the heart.

There are door trims on both the left and right sides of the hand rest seat, in addition to the centre of the heart.

On the back, there is a height-adjustable headrest. The seat dimension data in this study were obtained from the dealer's Engineering Department. The results of measurements performed by the author on a type Y vehicle. The dimensions are a 38 cm high seat with a backrest slope of 103. These dimensions have become complaints from customers who use type Y vehicles with a backrest height of 70 cm. The dimensions of the second row of type Y vehicles are shown in Figure 1.

The Stages of Making Modeling

So that the model made can describe the actual situation. It is necessary to carry out the model's stages to guide the modelling process. The stages of modelling are shown in Figure 2.

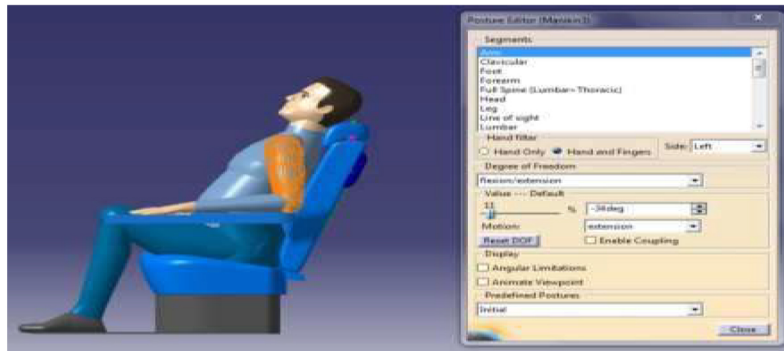

Figure 3: Design of sitting position.

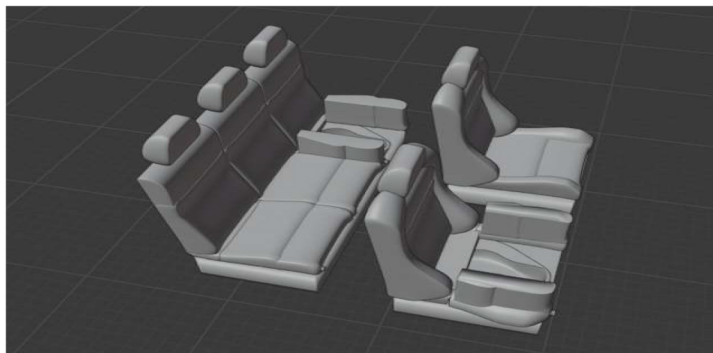

Figure 4: Car seat toilet emergency design.



Figure 5: Car seat emergency toilet design from the front.

In The Picture of The Process of The Modeling Stages Above, At First, This Stage Begins with The Manufacture of a Mannequin Model. After Doing the Modeling of The Mannequin, The Next Step Is to Make the Modeling for The Seat. Then Position the Modeling Mannequin That Has Been Made Against the Modeling Chair or Seat That Has Been Made. A Posture Analysis Will Next Be Performed Using the Catia Software's Human Activity Analyzer.

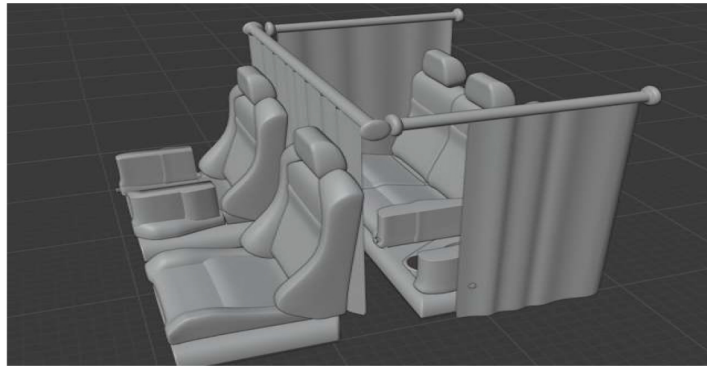

Figure 6: Car seat emergency toilet design complete.

CONCLUSION

The emergency toilet is a toilet located on a car seat that can be used in an emergency or emergency. The purpose of this toilet is to provide a toilet solution even in traffic jam conditions that prevent the driver or passenger from exiting the car.

The size of the toilet is designed to adjust the size of the car seat ergonomically. The complete materials and materials will be discussed in the progress report and final research report.

REFERENCES

- Agnes Sawir. 2003. "Analisis kinerja keuangan dan perencanaan keuangan perusahaan". Jakarta: PT Gramedia Pustaka Utama
- Bridger, R.S. (1995). Introduction to Ergonomics. McGraw-Hill, Inc. New York
- Folds, Dennis. Gardner, Douglas and Deal, Steve. (2008). Building Up to the Human Systems Integration Demonstration, INCOSE INSIGHT Volume 11 No. 2.
- Honour, Eric C. (2006) "A Practical Program of Research to Measure Systems Engineering Return on Investment (SE-ROI)", Proceedings of the Sixteenth Annual Symposium of the International Council on Systems Engineering, Orlando, FL.
- Mahdalena, Nina Martha. (1994). Evaluasi Ergonomi Fasilitas dalam Ruang Kemudi Mobil dengan Data Antropometri Orang Indonesia. Jurusan Teknik Industri ITB. Bandung.
- McCormick, Ernest J. (1976). Human Factors in Engineering and Design. McGraw-Hill, Inc. New York.
- Meilich, Abe. (2008) INCOSE MBSE Initiative Status of HSI/MBSE Activity (Presentation)
- Morlok, E. K. 1992. Pengantar Teknik dan Perencanaan Transportasi. Jakarta: Erlangga.
- Munawar, Ahmad. 2005. Dasar-Dasar Teknik Transportasi. Yogyakarta: Beta Offset.
- Mustikarani, W. (2016). Lalu Lintas Di Sepanjang Jalan H Rais a Rahman (Sui Jawi) Kota Pontianak. Edukasi, 14(1), 143–155.
- Mustopadidjaja. (2002). Manajemen Proses Kebijakan Publik Formulasi, Implementasi, dan Evaluasi Kinerja. Jakarta: LAN
- Nurmianto, Eko. (1996). Ergonomi Konsep Dasar dan Aplikasinya. Edisi Pertama. Guna Widya. Surabaya.

- Salvendy, Gavriel. (1997). *Handbook of Human Factor and Ergonomics Book 1*. New York: John Wiley & Sons, Inc.
- Sari, F. A. P. (2011). Analisis Kebijakan Penanganan Kemacetan Lalulintas Di Jalan Teuku Umar Kawasan Jatingaleh Semarang Dengan Metode Analisis Hirarki Proses (AHP). Universitas Diponegoro.
- Sonandi, Iwan A., Meriastuti Ginting, & Budi Marpaung. (2012). Perancangan Ergonomis Tempat Tidur Rumah Sakit. *Jurnal Ilmiah Teknik Industri*, Vol. 1 (2), 95–102.
- Stanton N., Alan H., Karel B., Eduardo S., & Hal H. (2005). *Handbook of Human Factor and Ergonomics Methods*. United States of America: CRC Press.
- Sukarto, H. (2006). Pemilihan Model Transportasi di DKI Jakarta dengan Analisis Kebijakan “Proses Hirarki Analitik.” *Jurnal Teknik Sipil*, 3(1), 25–36.
- Susanto, Sylvana S. (2002). Pendekatan Ergonomi dalam Perancangan Kabin Lokomotif untuk Meminimasi Kemungkinan Kecelakaan Kereta Api untuk Designed Induced Human Error. Jurusan Teknik Industri Unpar. Bandung.
- Sutalaksana, Iftikar Z.; Anggawisastra, Ruhana; dan Tjakraatmadja, John H. (1979). *Teknik Tata Cara Kerja*. Bandung: Departemen Teknik Industri, ITB
- Tahir, A. (2005). Angkutan Massal Sebagai Alternatif Mengatasi Persoalan Kemacetan Lalu Lintas Kota Surabaya. *Jurnal SMARTek*, 3(3), 169–182. Retrieved from <http://jurnal.untad.ac.id/jurnal/index.php/SMARTEK/article/view/365> (accessed on march 2021)
- Taubman, Philip. (June 25, 2008) Top Engineers Shun Military; Concern Grow. The New York Times Website: <http://www.nytimes.com/2008/06/25/us/25engineer.html> (accessed on Nov 2021)
- Ulrich Karl T., & Steven D Eppinger. (2008) *Product Design & Development* (Fourth Edition). New York: Mc Graw Hill
- Ulrich, Karl T and Steven D Eppinger, 2001. *Perancangan dan Pengembangan Produk*, Terjemahan oleh Nora Azmi dan Iveline Anne Marie, Penerbit Salemba Teknika, Jakarta
- Widodo, Imam Djati, 2003. *Perencanaan dan Pengembangan Produk*, TIM UII Press, Yogyakarta
- Z.Tamin, O. (1992). Ofyar_pemecahan kemacetan di kota besar.pdf. *Perencanaan Wilayah Dan Kota*, 3(4), 10–17.